

WOODHAVEN

GENERAL INSTRUCTIONS

Some routers will require cocking one handle in and partially under the table followed by the other handle, unless the handles can be removed. **"D" handle or pistol grip routers will not work on our plate in a table unless the handle is removed.**

STORING THE ROUTER - READ ME!!!!

Our plates are resistant to sagging and flexing during use. **However, long term storage of your router in the table is not advisable. Prolonged hanging may cause the plate to sag, proving again that gravity works.**

After use, store the router (leave the plate attached) in an upright position with the plate laying on a flat surface.

147 OR 147AP INSERT PLATE - PATENT #5,699,844

Be sure the O-ring is installed completely in the groove of the router plate. We install the O-ring at our factory, but sometimes they partially work their way out during shipping.

Before installing an insert, first determine which side of the insert is the bottom. The bottom of the insert has a machined face that is either black or dull yellow. The insert snaps into the opening in the plate. Install the insert by placing a bottom edge of the insert, at an angle, down into the opening and then pressing the opposite edge into place.

Turn the insert 1/4 turn to be sure it is seated on the O-ring. Test to be sure that it is held in place and will not fall out. Extra inserts are available.

To remove the insert, reach underneath the plate and press up, or insert a flat blade screwdriver in the slot in the insert from above the plate and pry out.

If the insert falls out, lifts out or turns without resistance, or the insert will not seat properly in the opening, then replace the O-ring. The O-ring is a wear item and will need to be replaced periodically. Always check that the insert fits properly before using the router. **DO NOT** use the plate if the insert is loose!

STARTING PIN

The starting pin is used with piloted type bits to aid in **starting** the cut in an odd or irregular shaped piece where it is impossible to use a router fence. It is a safety device and should be used in lieu of trying to start the cut freehand. If there is more than one starting pin hole in your router plate, always use the one to the right of the router bit.

Router Plate Instructions

Please Read Carefully!



Parts List

| Quantity | Item |
|----------|-----------------------|
| 1 | 147/147AP |
| 1 | 101A Starting Pin |
| 1 | 140R O-ring, in plate |

Plate Inserts

| | |
|---|---------------------|
| 1 | 140B Blank Insert |
| 1 | 140D 1-3/16" Insert |
| 1 | 140E 2" Insert |

Router Mounting

Please Read Carefully!

LAYOUT, MARK & DRILL PLATE

Side "B" is the side of the plate the router attaches to. Side "A" is the working side of the plate and must be countersunk for the mounting screws.

If the router base plate from your router is removable, it can serve as the template for marking the mounting hole locations on the Woodhaven plate.

Put masking tape on the Woodhaven plate at the approximate locations of the mounting holes. Remove the base plate from your router and place the working side of this plate against side "B" of the Woodhaven plate (label side of the 147 or similar table mounted plates, grooved and unlabeled side of the 577P or 578P).

Center the opening in your router base plate with the opening in the Woodhaven plate. If they are within 1/32" of being centered to each other that is usually adequate, except for bushing work.

Verify the handle, switch and other control locations before marking and drilling the plate. Some routers should have the handles mounted diagonally.

Tape the router base plate to the Woodhaven plate and mark the mounting hole locations on the masking tape. Use a center punch to mark the hole locations on the plate for drilling.

If your router base plate is not removable, lay out the mounting hole locations by carefully measuring. We show some bolt pattern charts with dimensions on the following page. Verify all dimensions before marking and drilling the plate.

- Mark and drill from side "B" (router side).
- Countersink holes from side "A" (working side).

ATTACH ROUTER TO PLATE

Remove your router's existing base plate, unless it's glued on, or your router's sub-base has protruding ribs which prevent the Woodhaven plate from laying flat. In either of these cases, leave the existing router base plate on and attach the Woodhaven plate over it.

Use longer flat head mounting screws to compensate for the additional thickness of the Woodhaven plate. You should use at least three screws to mount your router (except trim routers - two screws are adequate) to the plate.

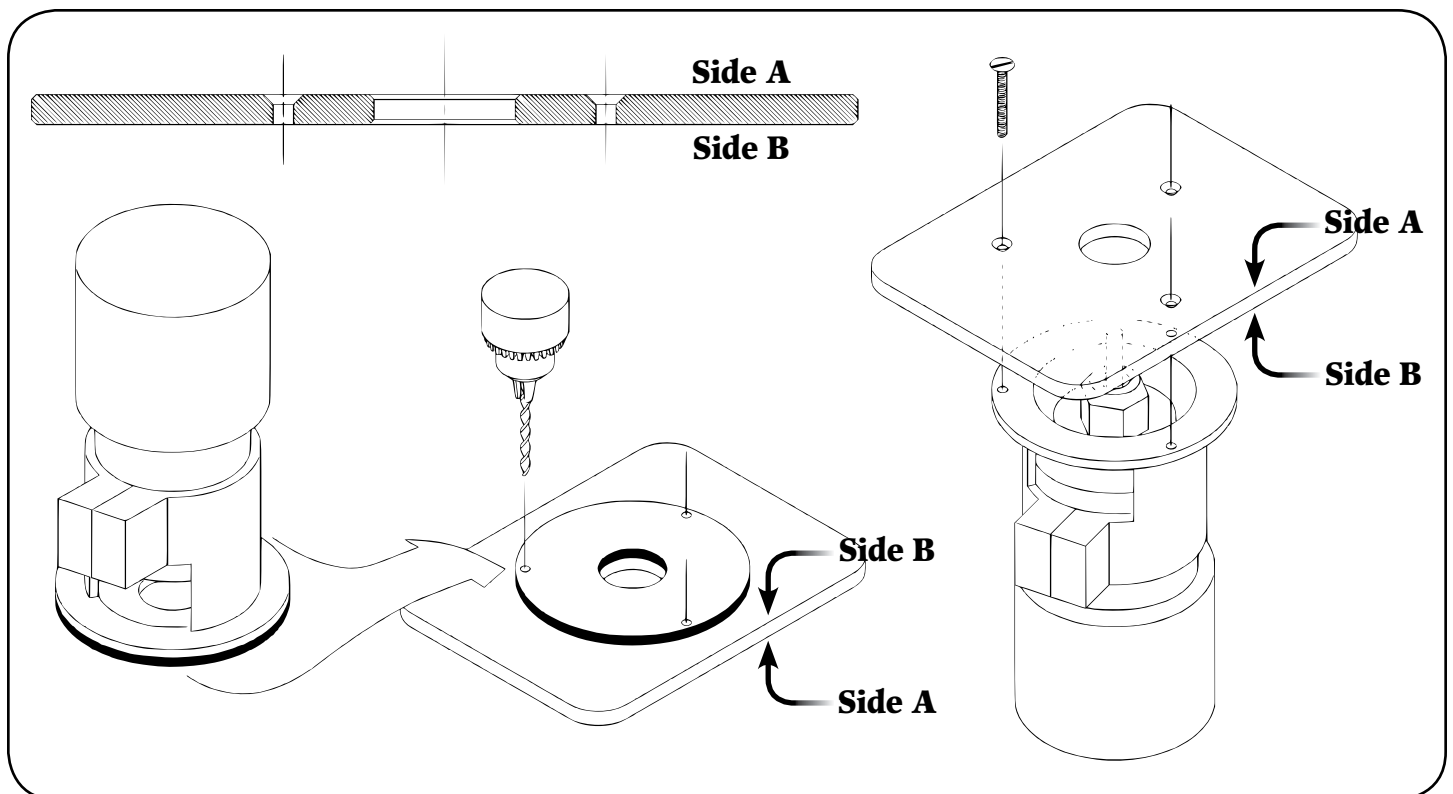
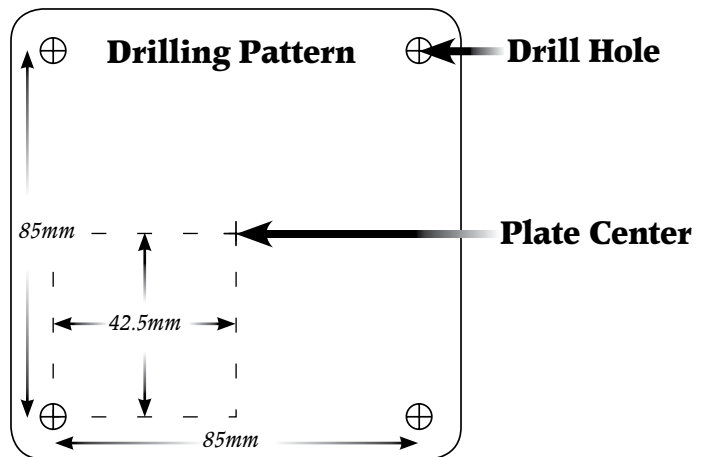

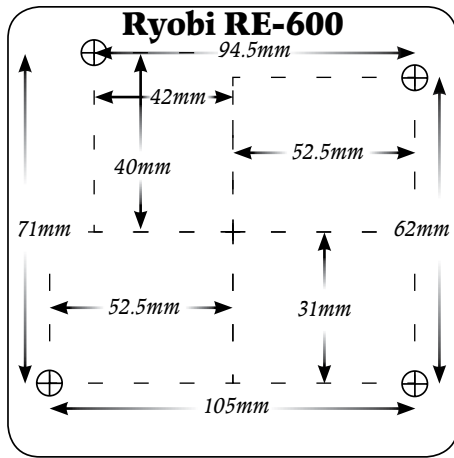
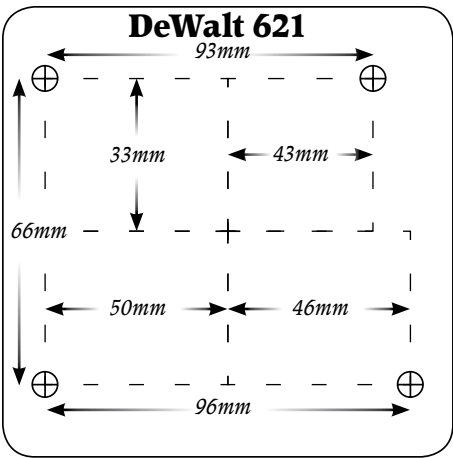
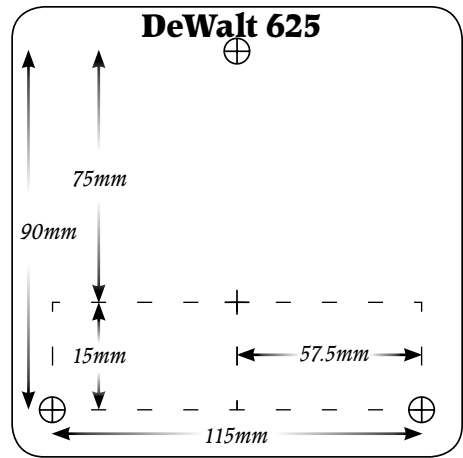
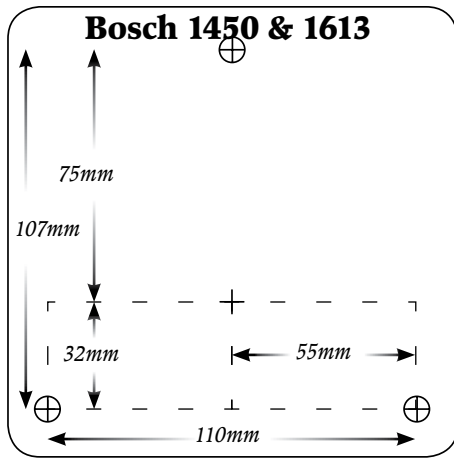
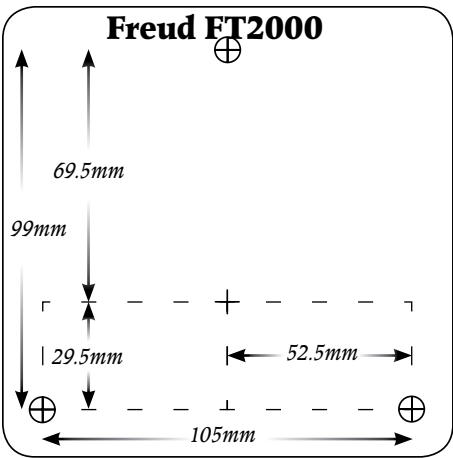
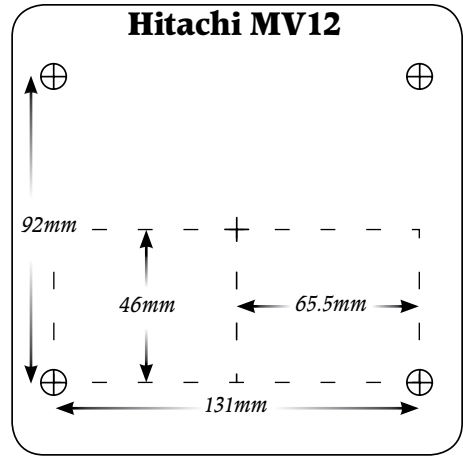
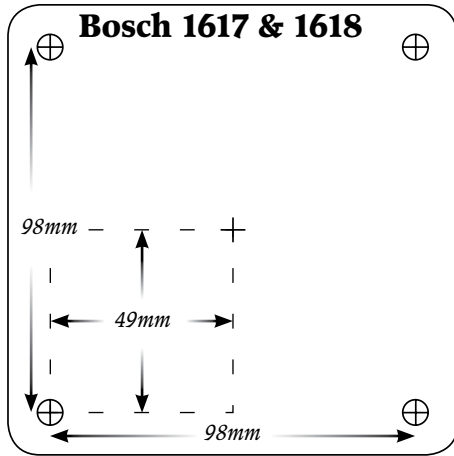
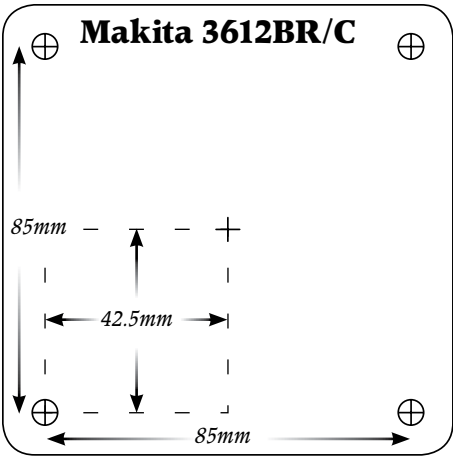
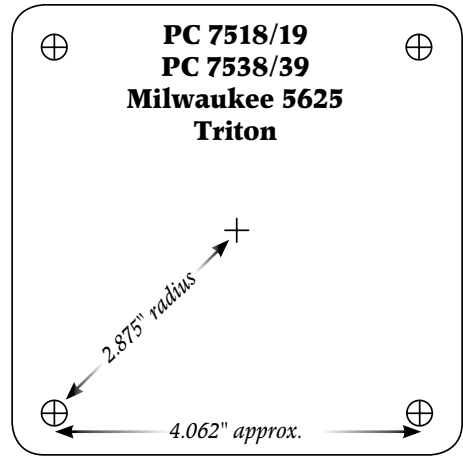
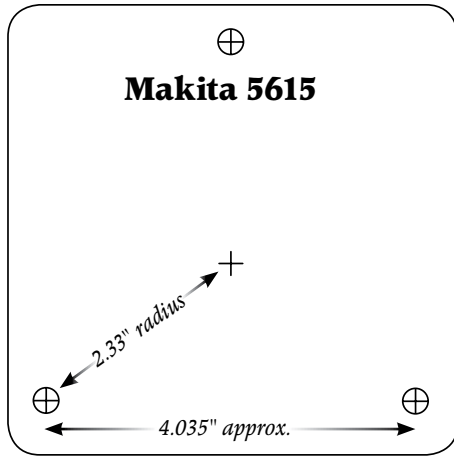
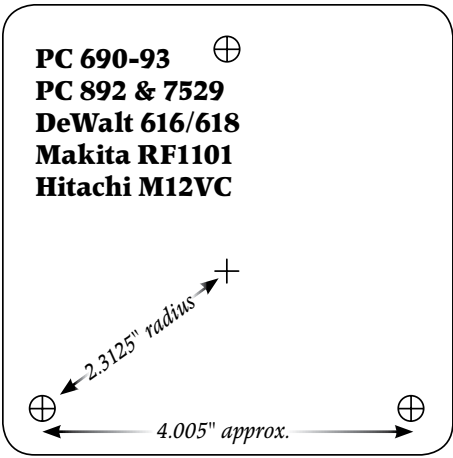

Router Table Instructions

Please Read Carefully!

The Woodhaven router table you have purchased is one of the best investments you can make in your shop. We hope you enjoy this product and are able to put it to good use. To aid you in getting the most out of this router table we have prepared this brief instruction sheet. Please read it carefully.

1. INSPECT THE ROUTER TABLE

We take every precaution to insure that your router table arrives in the same condition it was sent. After unpacking your table, inspect it for any damage caused in shipping. Dented edges or marks in the surface are some signs of shipper damage. If you purchased the table directly from Woodhaven, call us and we will let you know what to do next. If you purchased the table from one of our dealers, call them.

2. INSTALL MITER TRACK

If your table includes an aluminum T-Slot Miter Track, attach it to the table using the screws provided. The screws are self-drilling and don't require a pilot hole. A power screwdriver may be used too, but be careful not to strip the holes.

3. MOUNT THE TABLE

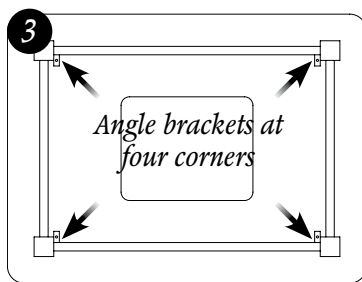

The router table needs to be properly supported to insure that it stays flat. This requires a well designed support frame, which Woodhaven leg sets and cabinets provide. Attach the table to your homemade leg set using four (or more) 1" angle brackets. We

recommend you place the angle brackets at, or near, the four corners of the router table. *See fig. 3.* You can screw into the bottom of our MDF tables, but not into the edge. Our Phenolic tables have T-slots machined in the bottom for attaching it to a leg set with angle brackets.

4. TABLE SAW ROUTER TABLES

These router tables can be mounted on the right or left side of the table saw and may be trimmed shorter to suit your needs. Sometimes a support frame can be attached to the fence rails of the table saw. *See fig. 4A.* If not, you will need an inboard bracket that attaches to the table saw. *See fig. 4B & 4C.* It will also need legs or braces to support the outboard end of the frame/table. *See fig. 4D.*

5. TABLE FLATNESS SPECS

Our tops are guaranteed flat to within .001 (one thousandths of an inch) per 1" of table length. For example, a 24" x 32" table can be up to .024" out of flat across the 24" width and up to .032" out of flat across the 32" length and still be within our specs. It is rare for a table to be that far out of spec and if it does warp it will usually only be in one direction. An exception to our flatness specs is a table with a miter slot. *These can warp along the length of the slot. We do not guarantee table flatness on these tables because cutting a miter slot relieves stress on one side of the table and can cause it to warp.* The good news is that it is easily re-flattened.

If your table is warped slightly but within our specs, or warped along the miter groove, it can be re-flattened by pulling the "high" part of the table down and/or applying shims between the leg rail and the underside of the table to force the "low" part of the table up. *See fig. 5.*

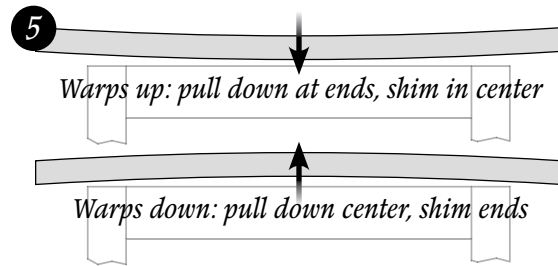

If your table is out of spec we will replace it, provided that it is not warped along the miter slot and it has been mounted to one of our leg sets or cabinets, or a leg set that meets our design criteria for support.

