

WOODHAVEN

790XL

Dado Jig

Owners Manual

Please Read Carefully!

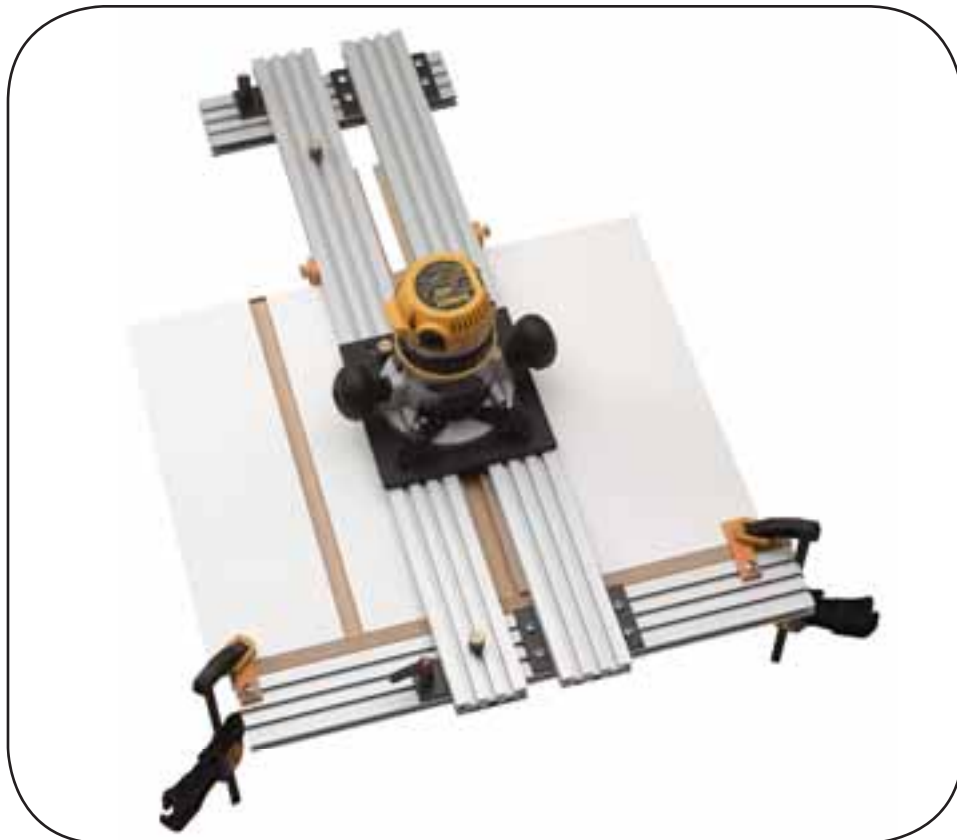

790XL Dado Jig Hardware List:

Identify and verify that you have all of the hardware shown below prior to assembly.

Tools needed for assembly: #2 & 3 Phillips screwdriver

Please read the instructions at least once, familiarizing yourself with the parts before beginning.

Additional 790XL Parts List:

Parts listed below are not shown in the hardware list drawings. Refer to photos in the instructions:

Part	Description	Quantity
789A	1/4" Fence	4
789B	Plate Guide	1
789C	Track Connectors	4 pc. set
789D	Edge Fence	4
789E	Work Stop	2
789F	Clamp Pad	2
789G	Clamp Pad	1
789N	Track	1
789P	Router Plate	1
4973	Router Plate Hardware	1
4412	12" Ultra Track	1
4448	48" Ultra Track	1
4460	60" Ultra Track	2

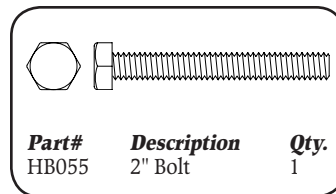
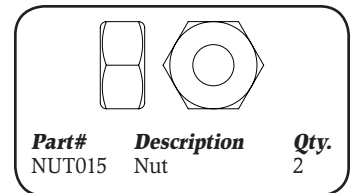
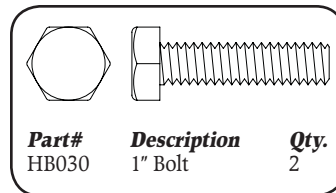
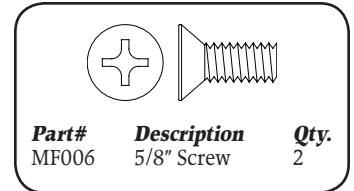
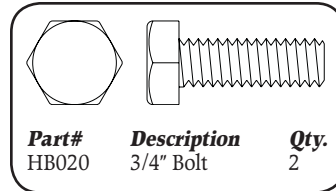
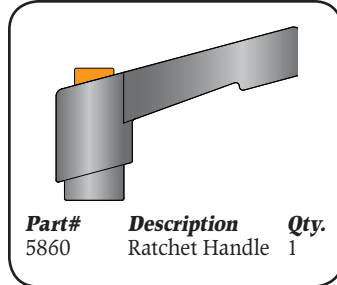
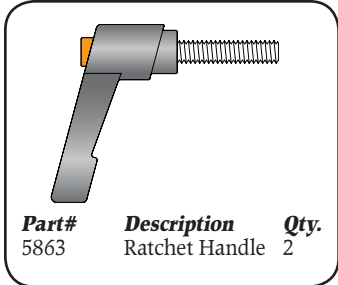
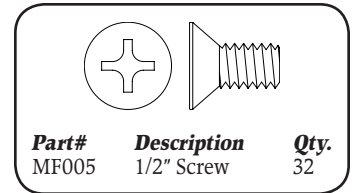
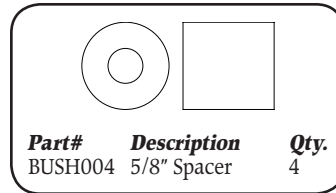
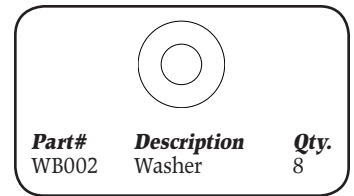
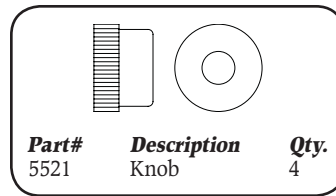
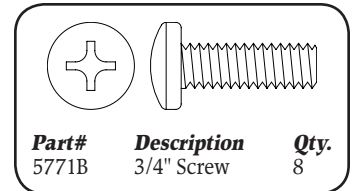
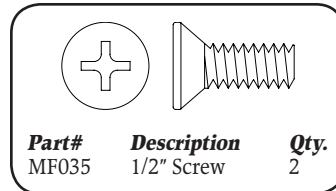
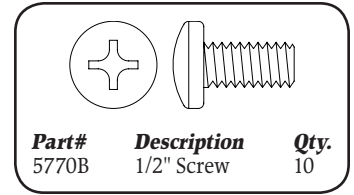
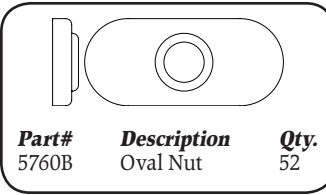

1. ATTACH 1/4" FENCES

Attach two 1/4" Fences (789A) to each of the 60" Ultra Tracks (4460). Insert a 1/2" screw (MF005) thru the countersunk holes in the 1/4" Fence and start an oval nut (5760B) on the end of each screw. Slide the Fence onto the Ultra Track so the oval nuts are captured in the T-slot as shown. Center the Fences end for end on the Ultra Tracks for now. They will be re-positioned later. *See fig. 1 & 2.*

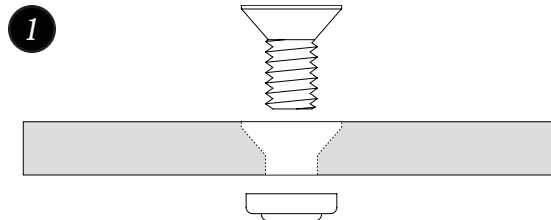

2



4460 - 60" Ultra Track with 1/4" fences attached

2. ATTACH TRACK CONNECTORS

Attach the Track Connectors (789C - 4 pc. set) to the 60" Ultra Tracks (4460). Insert a 1/2" screw (MF005) through the holes indicated on each Track Connector and start an oval nut (5760B) on each screw. *See fig. 3.*

3. Attach the Track Connectors to the Ultra Tracks as shown. The long leg of each Connector should be flush with the ends of the track. Check that the Connectors are square to the long edge of the track as well. *See fig. 4.*

These assemblies will now be referred to as the *Adjustable Track* and the *Stationary Track*.

3

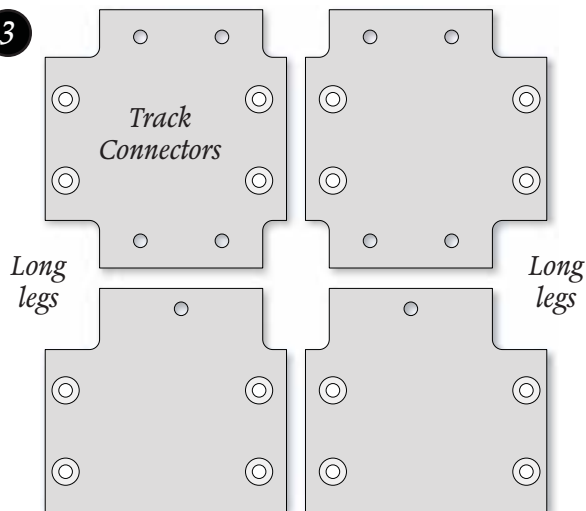

4

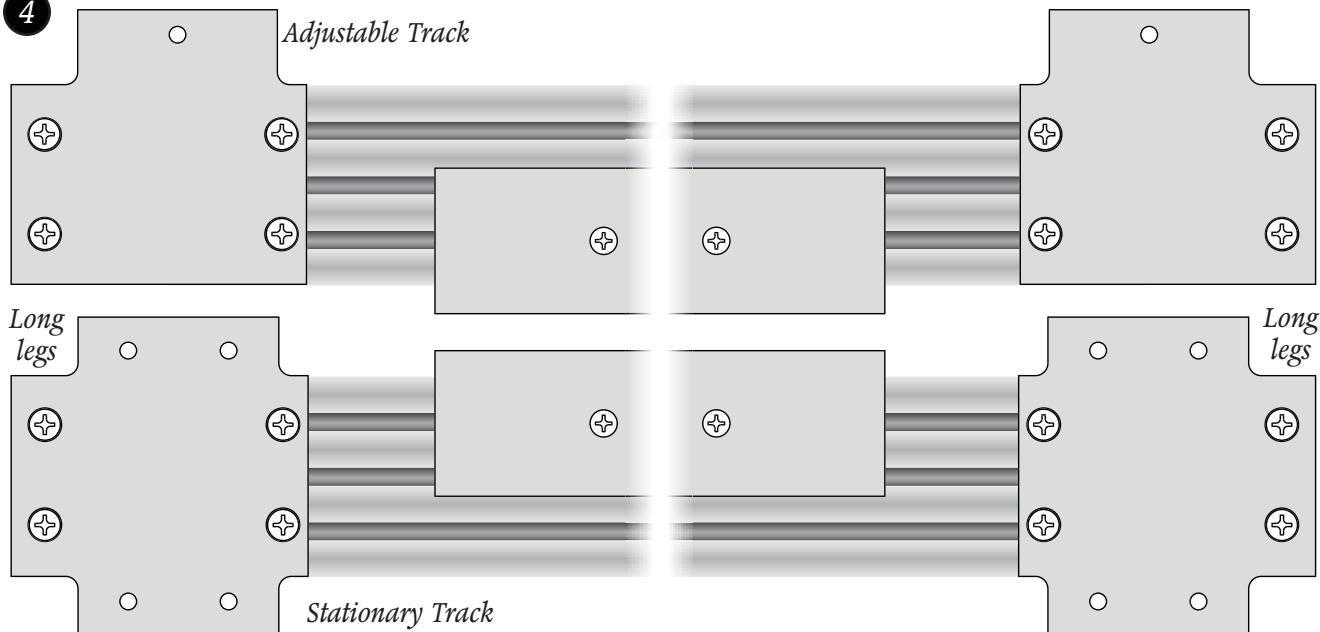

5. ATTACH WORK STOPS

Attach a Work Stop (**789E**) to the edge of the Adjustable & Stationary Tracks. Insert a 3/4" bolt (**HB020**) in the T-slot on the edge of each Track, sliding the bolt to the approximate center of the Track. Install a Work Stop on each bolt and fasten with a knob (**5521**). *See fig. 5.*

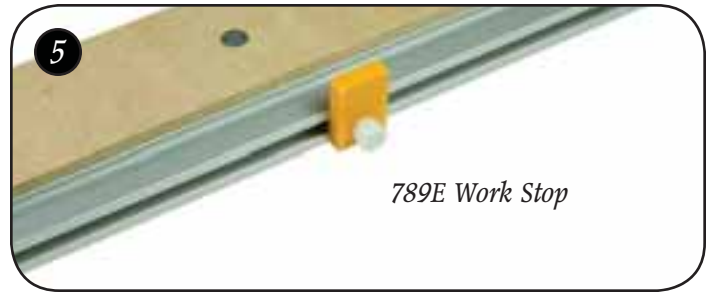

6. ASSEMBLE & INSTALL CLAMP PAD

Insert the 5/8" screws (**MF006**) through the holes in the clamp pad (**789G**) and start a nut (**NUT015**) on the end of each screw. Slide the nuts in to the T-slot of the track (**789N**) and tighten the screws. This forms the Clamp Pad assembly.

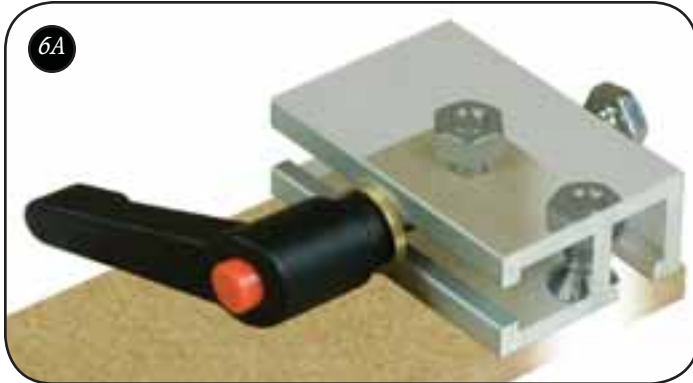

Insert the 2" bolt (**HB055**) in the outward facing T-slot of the Stationary Track of the Dado Jig Plus. Position the bolt so its between the front Edge Fence and the Work Stop.

Install the Clamp Pad assembly on the bolt, install two washers (**WB002**) on the bolt, then install the ratchet handle (**5860**) on the end of the bolt. *See fig. 6A & 6B.*

7. ASSEMBLE THE FRONT TRACK

Attach four Edge Fences (**789D**) to a 48" Ultra Track (**4448**) using 3/4" screws (**5771B**) and oval nuts (**5760B**). Insert the screws through the counterbored holes in the Edge Fence and start the oval nuts on the ends. Slide the Edge Fence onto the edge of the Track, capturing the oval nuts in the T-slot. Center them and tighten. This assembly will now be referred to as the **Front Track**. *See fig. 7.* The remaining 12" Ultra Track (**4412**) will be referred to as the **Back Track**.



8. ATTACH STATIONARY TRACK

Attach the Front and Back Tracks to the Stationary Track. Install 1/2" screws (**5770B**) through the holes in the Track Connectors on the Stationary Track. Start an oval nut (**5760B**) on the end of each screw. Slide the Front and Back Tracks on the oval nuts. Slide the Stationary Track on to the 48" Front Track so it's approximately 19 to 19-1/2" from the end of the 48" Track. Square both the Front and Back Tracks to the Stationary Track and tighten the screws. The Stationary Track will remain in this position. The instructions show the Stationary Track on the left, but you can choose to assemble the Stationary Track on the right. *See front cover and fig. 8, 789 shown.* Check the tracks periodically for square.

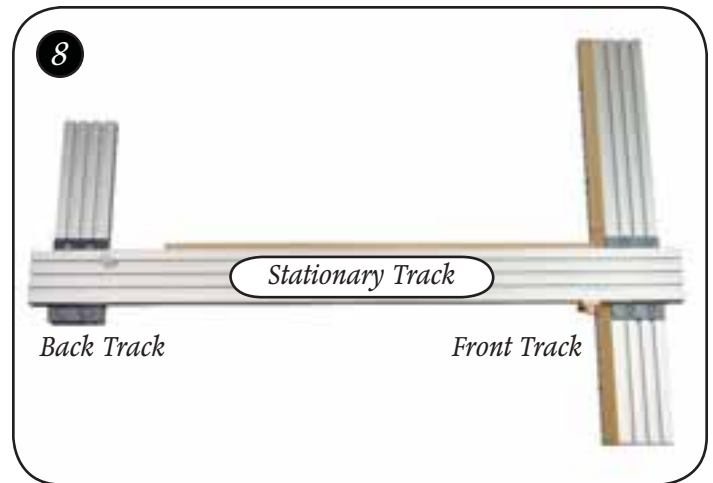

9. ATTACH ADJUSTABLE TRACK

Attach the Adjustable Track to the Front and Back Tracks. Install a washer (**WB002**) and a 5/8" spacer (**BUSH004**) on each Ratchet Handle. Install the Ratchet Handles (**5863**) through the remaining hole in each Track Connector on the Adjustable Track. Start an oval nut (**5760B**) on the end of each Ratchet Handle. Slide the Adjustable Fence onto the Front and Back Tracks and tighten the Ratchet Handles. If necessary, the washer can be removed from the Ratchet Handle to get more threads in the oval nut, but make sure the stud of the Ratchet Handle does not bottom out in the Front and Back Tracks. *See fig. 9 & 10.*

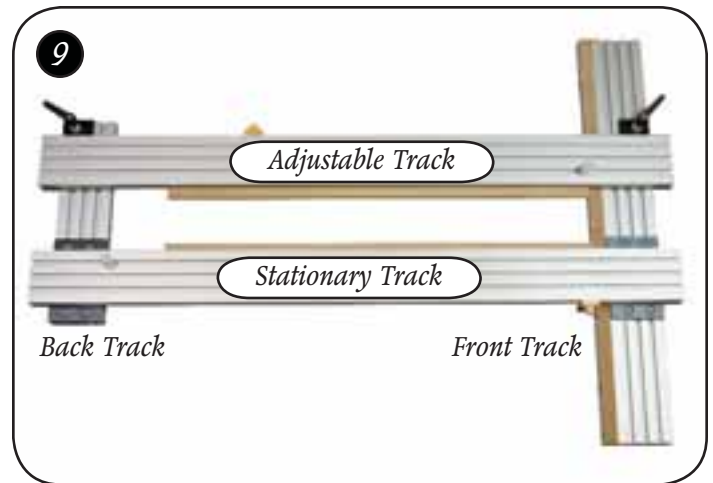

10. ATTACH CLAMP PADS & POSITION STOPS

Attach the Clamp Pads on the Front Track. Insert a 1/2" screw (**5770B only - no washers**) thru the hole in each Clamp Pad (**789F**) and start an oval nut (**5760B**) on the end of each screw. Slide the oval nut/Clamp Pad into the top front T-slot of the Front Track as shown. Position them where desired on the Front Track and tighten. Disregard the washers shown being used with the clamp pads in photo. *See fig. 10.*

Attach the Position Stops at each end of either the Stationary or the Adjustable Track. Use the 1" bolt (**HB030**), 5/8" spacer (**BUSH004**) and knob (**5521**). *See fig. 10.*

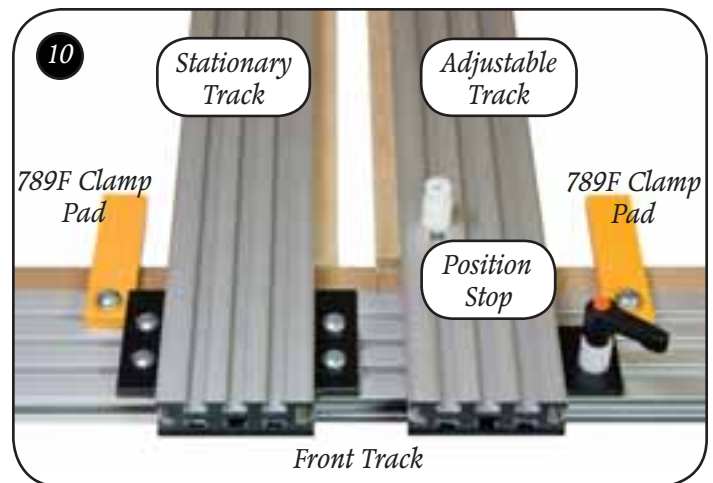

11. ATTACH PLATE GUIDE & ROUTER TO PLATE

Attach the Plate Guide (789B) to the Router Plate (789P) using the 1/2" screws (MF035). See fig. 11. Follow the directions in the 4973 Plate Hardware and attach your router to the Router Plate (789P). An optional drill style plate (PN 789PD) is available for semi-permanent mounting of your router but it requires drilling mounting holes in the plate.

SELECT ROUTER BIT - IMPORTANT!!!

This jig will work with any bit up to 3/4". The bit diameter should be no less than half the width of the dado to allow you to cut the dado in two passes. A 3/4" bit will cut dados up to 1-1/2" wide in two passes. If your dado is wider than twice the bit diameter, you'll have to make extra passes. A 1/2" bit (range 1/2" to 1") or 5/8" bit (range 5/8" to 1-1/4") is fine for 3/4" dados. A 3/8" bit (range 3/8" to 3/4") or 7/16" bit (range 7/16" to 7/8") may suit your needs better. Smaller diameter bits may limit the depth of the dado you're able to cut. **Once you select a bit, the jig should never be used with another bit without installing another set of 1/4" Fences and going through the trim operation.** You can make additional 1/4" Fences yourself, or you can order them (789A) from Woodhaven. Install the bit in your router and set the depth of cut to just below the 1/4" Fences.

12. TRIM 1/4" FENCES

Loosen the 1/4" Fences and re-position them so the ends are butted up against the front of the Edge Fence on the Front Track. Tighten the screws. See fig. 12.

Rip a piece of scrap 1-1/2" wide x 24" long. Place it between the Stationary and Adjustable Tracks, resting on the 1/4" Fences. Loosen the knobs on the Adjustable Track and slide it over towards the Stationary Track, with the 1-1/2" wide scrap between them. Tighten the knobs and remove the scrap. See fig. 13.

Place the Router/Router Plate on the Tracks with the Plate Guide between the Tracks. Loosen the Position Stops and adjust the front Stop so the router bit will cut just a little over halfway into the Edge Fence on the Front Track. Adjust the back Stop so the router bit won't strike the Back Track.

Place the Dado Jig on a scrap board 3/4" thick x 10" wide x 24" long. Adjust the Work Stops so the board is sandwiched between them and the Front Track. See fig. 13. Clamp the Jig and scrap to a workbench using the Clamp Pads.

Place the Router/Router Plate on the jig against the back Position Stop, with the Plate Guide between the Stationary & Adjustable Tracks. Turn the router on and hold the Plate Guide against the Adjustable Track as you pull the router forward. When you contact the front Position Stop, slide the router to the left so the plate Guide is against the Stationary Track and push the router back to the back Position Stop. See fig. 16 & Cover.

USING THE JIG FOR DADOES

Perform at least one of the two steps below to prevent the jig from racking during use.

1. Position and use the 789M Outboard Clamp Pad according to section six.
2. Clamp the Back Track of the Dado Jig to the workbench, or bolt the Dado Jig to a workbench using the T-slots in the underside of the Front and Back Tracks.

Always check that the Front Track is square to the Stationary Track before beginning. You only need to loosen the Adjustable Track to set the jig for the dado width you want.

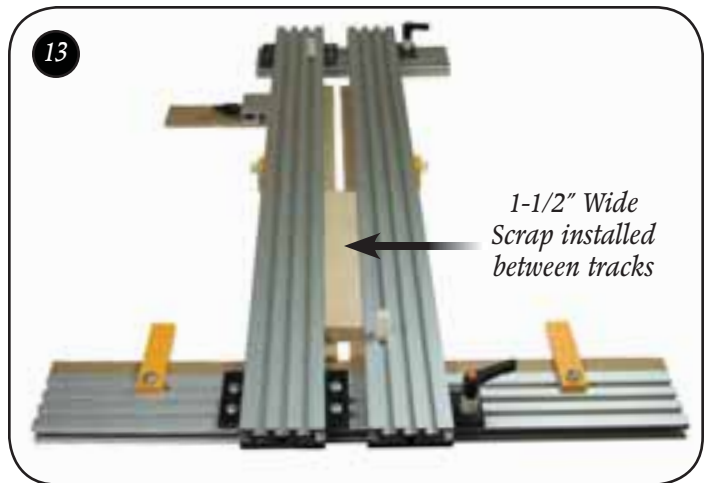

14. ADJUST WORK STOPS

Adjust the Work Stops to fit the width of stock you're using. *See fig. 14.* Select the workpiece you want to cut the dado for. Loosen the Adjustable Track and place the workpiece vertically between the 1/4" Fences. Slide the Adjustable Track so the workpiece is sandwiched between both 1/4" fences and tighten the knobs. Remove the workpiece from between the 1/4" Fences and cut the dado. *See fig. 15.*

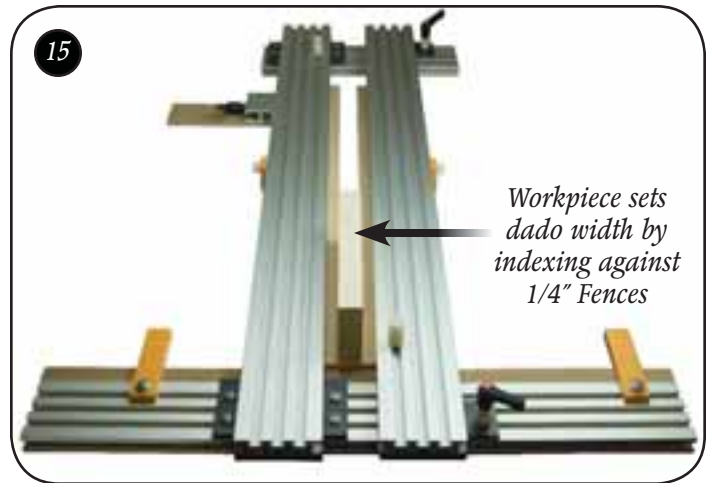
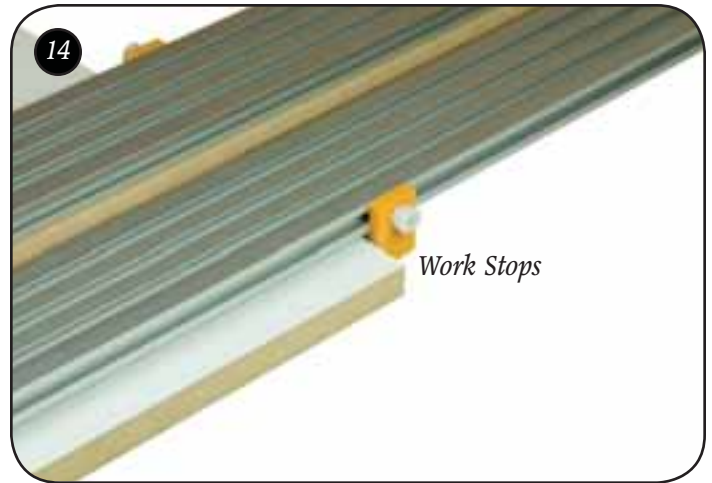

16

16. Dado Jig Operation

1. Place the Router/Router Plate on the jig against the Back Position Stop, with the Plate Guide between the Stationary & Adjustable Tracks.

1-2. Turn the router on and hold it against the Adjustable Track as you pull the router forward.

2-3. When you contact the front Position Stop, slide the router to the left against the Stationary Track.

3-4. Holding it against that track, push the router back to the Back Position Stop.

*See fig. 16 & Cover.
Continued on next page*

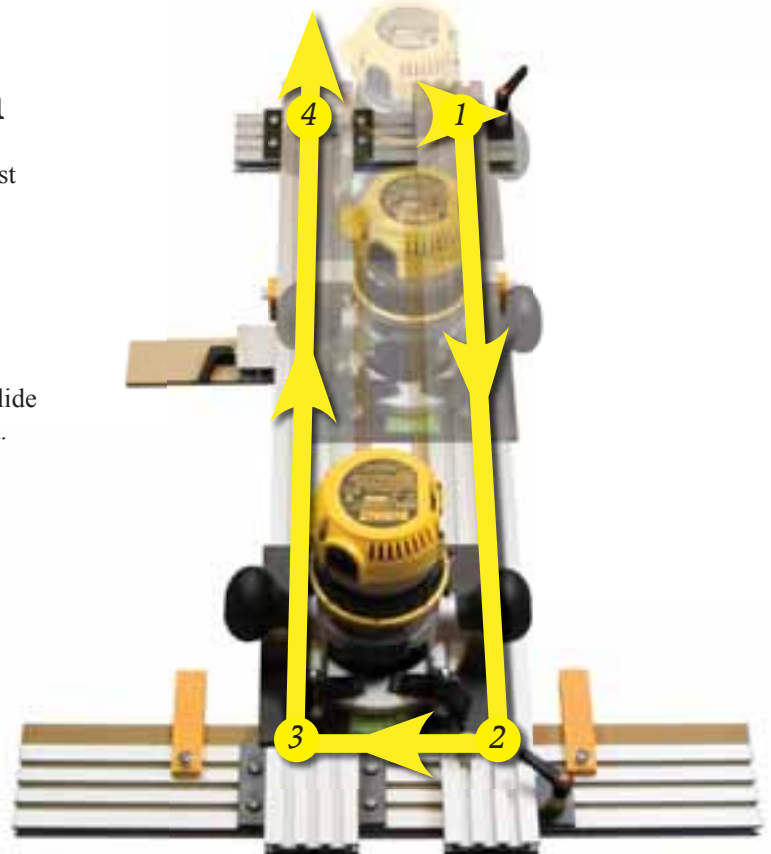

17. OTHER USES

By adjusting the Adjustable Track so the Router Plate/Plate Guide can't move side to side between the Adjustable and Stationary Track, you can use the jig for making flutes, sliding dovetails and other long straight cuts.

To cut angled dados, install an angled sub-fence to the clamp pads of the jig. To do this, drill a hole in each pad and attach the sub-fence to them with wood screws after all other adjustments have been made. You'll have to clamp the stock and the jig to the workbench separately. Note that an angled sub-fence will limit the width of stock that can be dadoed. You'll want to slide the edge fence as close to the narrow (pointed) end of the sub-fence to maximize the stock width that can be dadoed. *See fig. 17 & 18*

18. DADO JIG STOP ACCESSORIES

The Front Track of the Dado Jig can be extended on one or both ends. The extension can be ordered in twelve inch increments (*4424XL - 24" extension shown*) all the way up to 96" long. This allows you to attach Work Stops to the extra length of track to make cutting multiple dados easier. Please note the extension does not come with a stop by default, you must order them separately. You can order as many Work Stops (*789S*) as needed. *See fig. 19 & 20*

An additional accessory to our Dado Jig Extension is the *4523 Micro Adjuster*. It attaches directly to the *789S* stop and allows up to 5/8" of fine adjustment. *See fig. 20*

©Copyright WOODHAVEN INC. 10/02/07
(800) 344-6657 or WWW.WOODHAVEN.COM

