

# WOODHAVEN

## 7282 Hardware List:

Identify and verify that you have all of the hardware shown below prior to assembly.

Part#	Description	Qty.
BUSH525	1/4" Spacer	10

Part#	Description	Qty.
5760B	Oval Nut	8

Part#	Description	Qty.
BUSH050	3/8" Spacer	2

Part#	Description	Qty.
HB040	1-1/4" Bolt	4

Part#	Description	Qty.
BUSH001	1/8" Spacer	2

Part#	Description	Qty.
HB030	1" Bolt	2

Part#	Description	Qty.
WB002	Washer	6

Part#	Description	Qty.
5772B	1" Screw	4

Part#	Description	Qty.
MF025	1-1/2" Screw	8

Part#	Description	Qty.
NUT015	1/4-20 Nut	12

Part#	Description	Qty.
WL001	Lock washer	8

# 7282 Large Band Saw Fence Owners Manual

*Please Read Carefully!*

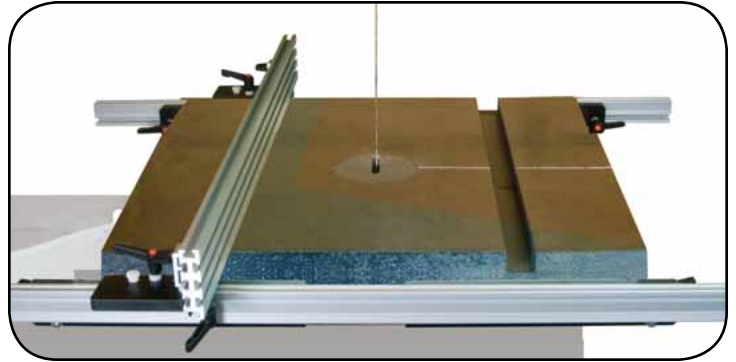

## Additional Parts List:

Parts listed below are not shown in the hardware drawings. Refer to photos in the instructions:

Part	Description	Quantity
7282A	Brackets, Left & Right	2 pair
7280B	Guides	1 pair
7280T	Track Bracket	2
4036	36" Double Track	2
4432	32" Ultra Track	1
4575	Track Stop	1

Part#	Description	Qty.
5503	Thumb screw	2

Part#	Description	Qty.
5540	Knob	2

Part#	Description	Qty.
5860	Ratchet Handle	2

Part#	Description	Qty.
5863	Ratchet Handle	6

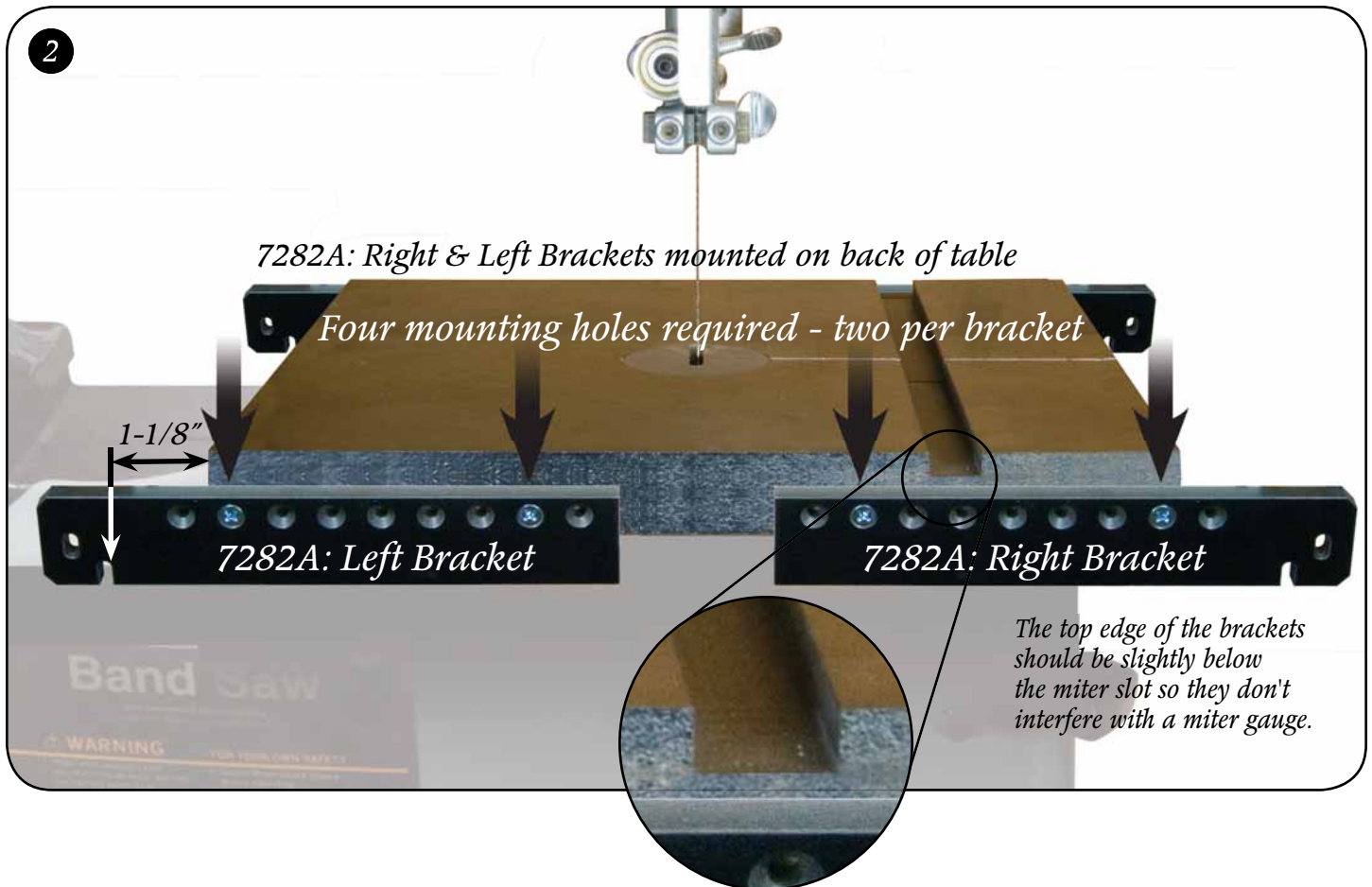

## BEFORE BEGINNING

Read the instructions at least once, familiarizing yourself with the parts before beginning. Tools needed for assembly: 1/4" drill bit & drill, 7/16" wrench and a #3 Phillips screwdriver. This Fence was designed for use with the 16" - 24" band saws with 16" to 28" deep (front to back) tables. The Large Band Saw Fence mounts by drilling holes in both the front and rear table edges. The requirements to mount this fence to your band saw are: **1:** The front and back table edges must be machined smooth (no indentations) and square to the top of the table. **2:** You are able to drill eight 1/4" mounting holes (four front and four back) in the table edge, 7/8" to 1" down from the table top. **3:** The brackets will hang approximately 2-5/8" below the table top so make sure they will not interfere with opening the lower door or any adjustment knobs in the front or back of the saw.

## ASSEMBLE THE FENCE

Scribe a line along the front and back edges of the band saw table, 1/2" (7/16" to 9-16" will work) below the top of the table and parallel to it. (An alternate method is to cut a 1/2" rabbet in a board that's the length of your band saw table. Clamp it to the top of the table so the rabbeted edge sticks down 1/2" below the top of the band saw table.)

Clamp the Left and Right Bracket (**7285A**) to the edge of the band saw table so the top of each Bracket is even with the scribed line. Position each Bracket so the inside edge of the slot (nearest the band saw table) is at least 1-1/8" away from the edge of the band saw table that runs front-to-back. If necessary, use a straight edge to line the top edges of the Brackets up. The Brackets can be cut shorter if necessary. *See fig. 2.*

Select two of the holes in each Left & Right Bracket (**7285A**) that will not interfere with ribbing or other obstacles under the band saw table for the mounting holes. Use the holes in the brackets as a drill guide and, using a 1/4" drill bit, drill four mounting holes in the both front and back edge of the band saw table. Mount the Brackets to the band saw table using a 1-1/2" screw (**MF025**), lock washer (**WL001**) and nut (**NUT015**) in each hole drilled. *See fig. 2.*

Install a 1/4" spacer (**BUSH525**) on the stud of four of the knobs (**5863**). From the back side, insert the stud thru the vertical slot in each Bracket and start an oval nut (**5760B**) on the end of each stud. *See fig. 3 & 4.*

Slide a 36" double track (**4036**) on each pair of oval nuts until flush with the end of the Bracket. Adjust the double track so it's 7/16" below the band saw table and tighten the knobs. *See fig. 3.*

Install a 1/4" spacer (**BUSH525**), washer (**WB002**) and nut (**NUT015**) on the four 1" screws (**5772B**). Slide the screw in the open slots in the bottom of both the front and back brackets. The Bracket will be sandwiched between the screw head/spacer in the front and the washer/nut in the back. Adjust them so the spacer is against the underside of the double track and tighten the screws. The spacers maintain the height of the track when the knobs are loosened, allowing you to shift the track left or right if needed. *See fig. 4.*

Get the pair of guides (**7280B**), which are mirror images of each other, and install 1" bolt (**HB030**) thru the hole shown on each guide. Install a washer (**WB002**), 1/8" spacer (**BUSH001**) and knob (**5860**) on the end of each bolt. Install a 1/4" spacer (**BUSH525**) on two of the knobs (**5863**). Starting from the smooth side of the guide, insert the stud of the knob thru the hole shown in the guide and start an oval nut (**5760B**) on the end of the stud. Insert a thumb screw (**5503**) into the threaded hole shown in the guide. This is used for squaring the fence later and may get moved to the opposite hole in the guide, or possibly not used at all. *See fig. 5.*

Attach the guides to the 36" double tracks. The rib of the guide and the oval nut will fit into the T-slot of the track. Position the guides on the tracks an equal distance from the end of each track and tighten the knobs. *See fig. 6.*

Slide the 32" Ultra Track (**4432**) onto the bolt heads on top of the guides until evenly spaced from each end and tighten the knobs underneath. *See fig. 7.*

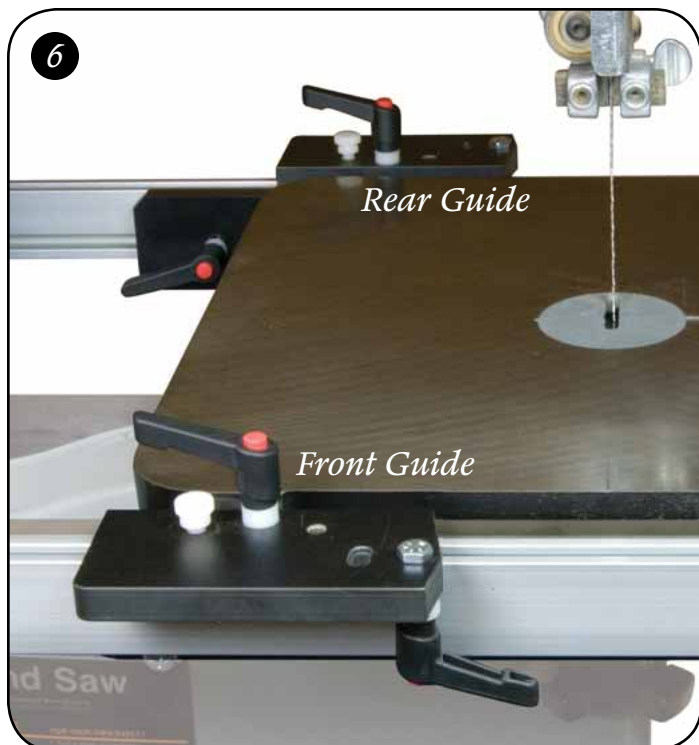
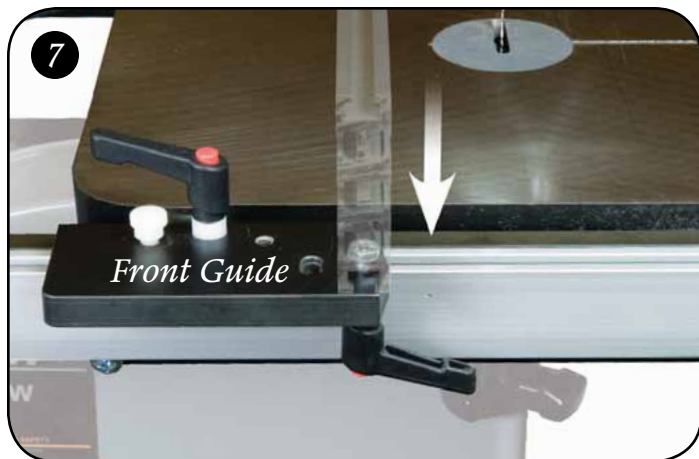
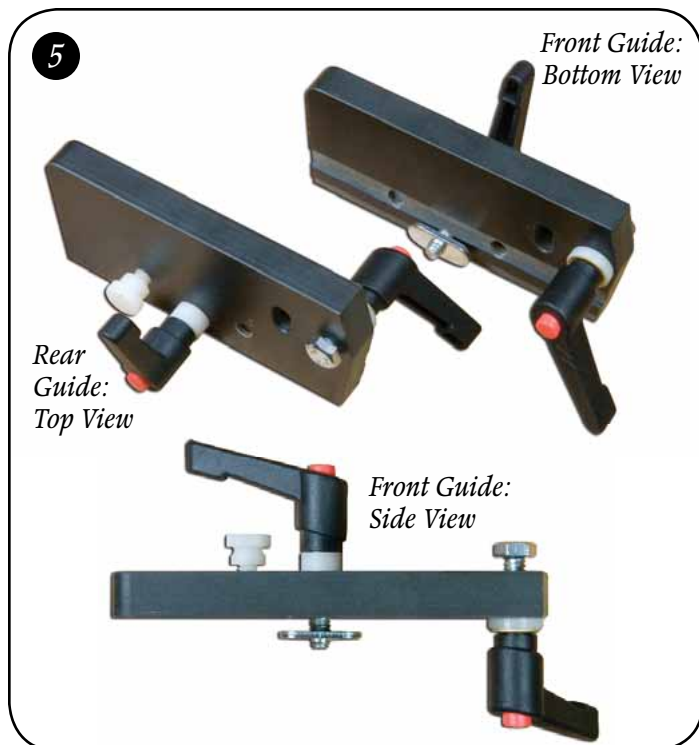
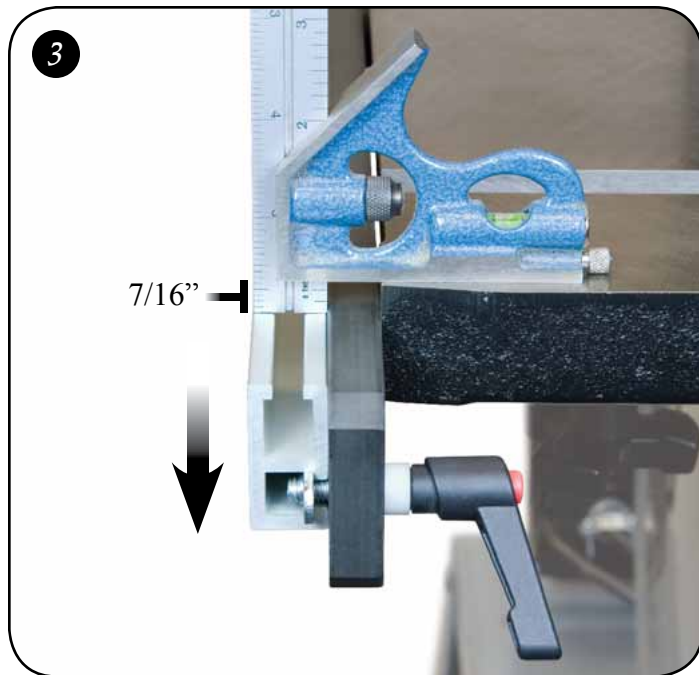

From the bottom of each guide, insert a 1-1/4" bolt (**HB040**) through the slot and install a 3/8" spacer (**BUSH050**) and an oval nut (**5760B**) on the bolt. *See fig. 7A*

Insert a 1-1/4" bolt (**HB040**) through the hole in each track bracket (**7280T**) and install a washer (**WB002**) and knob (**5540**) on each bolt. Slide the bolt head into the center T-slot of the Ultra Track Fence and the track bracket on to the oval nut on top of the guide. Along with the knob underneath the guide, tightening the track bracket knob and the bolt underneath the guide double locks the fence at the blade lead angle. *See fig. 7B & 7C.*

If desired, the fence can be adjusted for square vertically, but make sure the fence rails are parallel to the table top first. Turning the thumb screw (**5503 - installed earlier in the guide**) will raise the back of the guide, tipping the fence forward. Moving the thumb screw to the opposite hole (*closest to the fence*) will tip the fence back. Retighten the knobs and check for square. It may also be necessary to flip the Ultra Track fence over, or end for end, to get the fence square. Be sure to loosen the knobs clamping the guides to the double tracks **BEFORE** adjusting the thumb screws! *See fig. 8.*

### USING THE FENCE

The Ultra Track fence can be adjusted up to 10 degrees each way to compensate for blade lead. To determine your blades lead angle, draw a line parallel to the long edge of a 18-24" long board, 1-2" in from the edge. Without using the fence, start cutting on the line of the board. It will become apparent that you will have to angle the board slightly to follow the line. Stop cutting about halfway along the length of the board, hold (or clamp) the board in position, and stop the saw.

Loosen the knobs holding the guide to the tracks, plus the bottom knobs and bolts holding the Ultra Track to the guides. Butt the fence against the board to set the fence to your blades lead angle. Retighten the knobs holding the guides to the tracks first, then tighten the knobs and bolts underneath the guides that fasten the Ultra Track. *See fig. 9.*

By loosening the two knobs holding the guides to the double tracks, you can slide the fence left or right. Retightening the knobs will pull the fence back to the lead angle you set. By loosening the knobs holding the double tracks to the brackets, you can reposition them. By loosening the four knobs holding the Ultra Track fence, you can reposition it. Use the Track Stop on the Ultra Track fence when making stopped cuts.

We have a unique Circle Jig (**7287**) available that will cut circles as large as 47-1/2" in diameter without the need for a starting cut.

©Copyright WOODHAVEN INC. 11/17/08  
(800) 344-6657 or WWW.WOODHAVEN.COM

