

WOODHAVEN

202, 202T & 203 Router Fence

Please Read Carefully!

Parts List:

Please identify and verify that you have all of the hardware shown below prior to assembly.

Parts listed below are not shown in the hardware drawings. Refer to photos in the instructions:

Part	Description	Quantity
200C	Fence Base	2 pcs
200E	End Blocks	2
200D	Dust Port Blocks	2
281	Dust Port	1
200F	Dust Port Plate	1
202G	Guard Insert	1
3724RL	Tapes, L & R	1
224	Guard	1
200FS	Shims	4

You will also receive one of the parts below:

202A/203A	32" or 36" Aluminum fence	1
202B/203B	16" or 18" Fence faces	1 pr.
200SC	Fence Clamps for 202 & 203	
267	Table Saw Brackets for 202T	

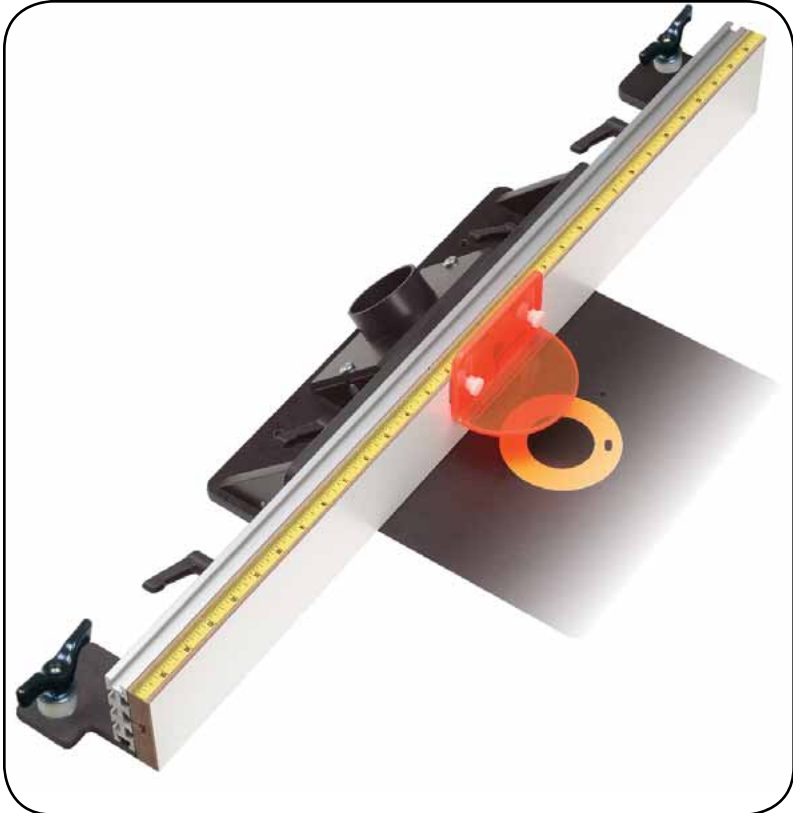
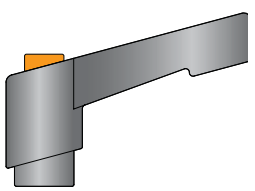
Part#	Description	Qty.
5860	Ratchet Handle	4

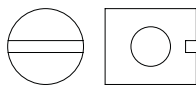

Part#	Description	Qty.
5793B	Barrel Nut	8



Part#	Description	Qty.
5720	2-1/4" T-Bolt	4

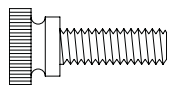

Part#	Description	Qty.
5505	Thumb Screw	2

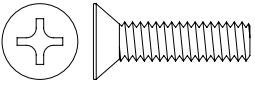

Part#	Description	Qty.
MF015	1" Screw	1

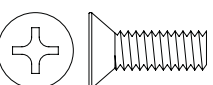

Part#	Description	Qty.
MF010	3/4" Screw	6

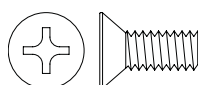

Part#	Description	Qty.
MF006	5/8" Screw	4



Part#	Description	Qty.
BUSH5050	1/2" Spacer	2

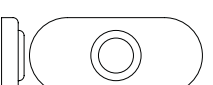

Part#	Description	Qty.
5760B	Oval Nut	5

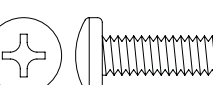

Part#	Description	Qty.
5771B	3/4" Screw	2

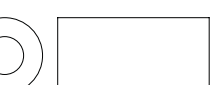

Part#	Description	Qty.
7310B	1" Spacer	2

FENCE ASSEMBLY

You'll need a #3 Phillips screwdriver for assembly. Get the two pieces of the Fence Base (200C) and the two End Blocks (200E). Assemble the Fence Bases and End Blocks together using four 3/4" screws (MF010) and four barrel nuts (5793B). Insert the screws through the counter-sunk holes in the fence base and start a barrel nut on the end of each screw. Slide each End Block onto the two of the barrel nuts and tighten the screws. *See fig. 1, 2*

Attach the Dust Port Blocks (200D) to the base assembly using two 3/4" screws (MF010) and two barrel nuts (5793B). Insert the screws through the counter-sunk holes and start a barrel nut on the end of each screw. Slide a Dust Port Block on to each barrel nut and tighten the screws. *See fig. 3*

Attach the Dust Port & Dust Port Plate (281 & 200F) to the Dust Port Blocks using two 3/4" screws (5771B) and two barrel nuts (5793B). Insert the screws through the mounting holes in the Dust Port Plate and start a barrel nut to the end of each screw. Insert the Dust Port into the opening of the Dust Port Plate (no need to glue it in place), insert the barrel nuts in the corresponding holes in the Dust Port Blocks and tighten the screws. *See fig. 3*

Insert four 5/8" screws (MF006) through the fence base and start an oval nut (5760B) on the end of each screw. Slide the Aluminum Fence (202A or 203A) on to the oval nuts until the bit opening in the Aluminum Fence aligns with the corresponding opening in the fence base, then tighten the screws. *See fig. 4*

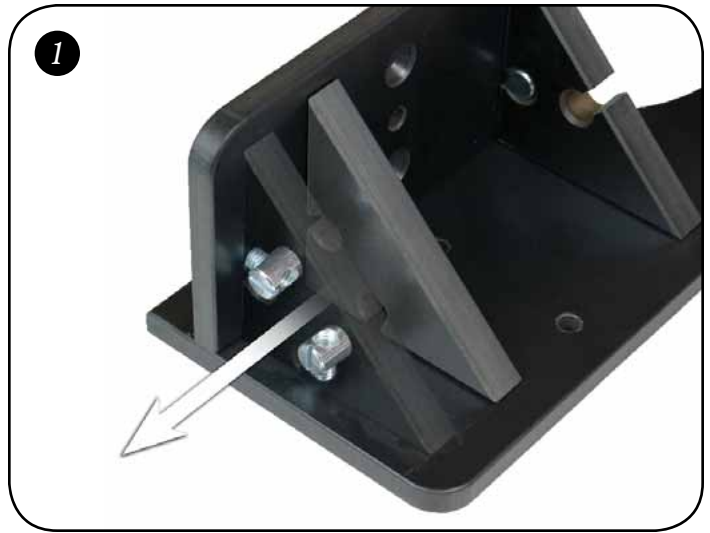

Insert the 1" screw (*MF015*) through the hole in the Guard Insert (*202G*) and start an oval nut (*5760B*) on the end of the screw. Slide the oval nut (*with Guard Insert*) in the upper T-slot of the Aluminum Fence, placed in the middle, and tighten the screw. *See fig. 5*

Insert the four T-bolts (*5720*) through the four holes in the face of the Aluminum Fence. Install a 1/2" spacer (*BUSH5050*) and a Ratchet Handle (*5860*) on the ends of the two T-bolts sticking out on either side of the Dust Port. On the two remaining outer T-bolts install a 1" Spacer (*7310B*) and then a Ratchet Handle (*5860*). *See fig. 6*

Slide the Left and Right Fence Faces (*202B or 203B*) onto the T-bolts (*one fence face from each side*) until they cover the Aluminum Fence. Make sure the fence faces and guard insert are butted together, then tighten the Ratchet Handles. *See fig. 6, 7*

Attach the pair of Left & Right Tapes (*3724RL*) to the top edge of these three pieces. The end of each tape (*next to "Woodhaven"*) must be cut to the zero line first. The tape numbers should face towards the front of the fence when installed. Peel back a small part of the paper backing on the tape and start the tape with the zero mark at the center of the guard insert, which should be centered on the edge of the fence face. Press down firmly on the tape, removing the paper backing as you go. Trim the tape overhanging the ends of the fence faces. Separate the fence faces from the guard insert with a knife.

Attach the Guard (*224*) to the Guard Insert using the two thumb screws (*5505*). *See fig. 9*

This completes assembly of the core fence components. To complete the fence, follow the directions that are included with the Fence Clamps (*200SC*) or Table Saw Brackets (*267*).



USING THE FENCE

It is not necessary for the fence to be clamped parallel to the table edge, or miter slot, unless you're using a miter gauge at the same time. Make sure the bit will not strike the fence before starting the router. The end of a standard shop vacuum hose (2-1/2") press fits in the dust port. Accessories are available to adapt to other hose sizes. If you won't be using a vacuum, remove the dust port and dust port plate so sawdust doesn't buildup inside the fence cavity and cause kickback.

The infeed fence (*right fence face*) can be turned in to a zero clearance fence that acts as a chip breaker. To do this, position the fence at the finished cut position, loosen the infeed fence slightly and slide it into the bit while its turning. **DON'T** make the outfeed fence a zero-clearance fence. You'll reduce the effectiveness of your vacuum, plus there's no chip breaking benefit on the outfeed side. *See fig. 10.* Pairs of replacement fence faces (*202B OR 203B*) are available.

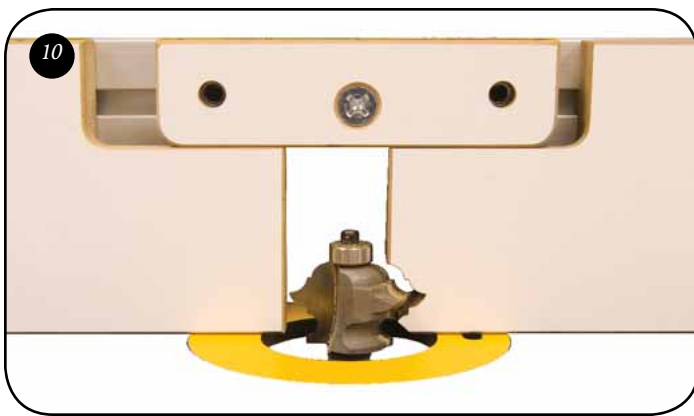

You can offset the outfeed fence face for jointing by using the shims (*200FS*). The shims are 1/32" thick and fit between the fence face and the aluminum fence, with the slots of the shims going over the T-bolts. *See fig. 11*



ACCESSORIES

The *240 Hold-Down & 242 Hold-In Featherboards* increase the safety and quality of your routing.

The *286 (2-1/2" - 4") Adapter* or *285 (2-1/2" to 3") Adapter*, plus a *282 Male Coupler*, are available if you are using a dust collector system with a 3" or 4" hose. See our website for these.

The *4519 Straight Stop & 4517 Stop Extension* provides a means to control stock travel when cutting stopped flutes, etc.

The *504 Glide Block* includes two heads. One is used as a hold-down/push stick, the other is used as a push block for cutting tenons, etc.

©Copyright WOODHAVEN INC. 11/12/08
(800) 344-6657 or WWW.WOODHAVEN.COM